

# PIVOT

Fotodispositivo infrarosso regolabile 210°

Adjustable infrared photocell 210°

Photocellule avec rotation 210°

Infrarot Lichtschranke schwenkbar bis 210°

Fotodispositivo infrarrojo ajustable 210°

**TAU**

>MOVING LIFE

Via E. Fermi, 43  
36066 Sandrigo (Vi)  
Tel. +390444750190  
Fax. +390444750376  
www.tauitalia.com



GUIDA ALL'INSTALLAZIONE - INSTALLATION GUIDE  
INSTALLATIONSANLEITUNG - NOTICE D'INSTALLATION  
GUÍA PARA LA INSTALACIÓN

## ALLINEAMENTO - ALIGNMENT - AUSRICHTUNG - ALIGNEMENT - ALINEACIÓN:

RISPETTARE ALTEZZE E DIREZIONE. Ad allineamento avvenuto il led sul ricevitore si spegnerà - OBSERVE HEIGHTS AND DIRECTION. After alignment, the LED on the receiver will put out - HÖHEN UND RICHTUNG BEACHTEN. Nach erfolgter bündigen Einbau, wird die LED am Empfänger ausschalten - RESPECTER LES HAUTEURS ET LA DIRECTION. Quand l'alignement est effectué, la LED sur le récepteur s'éteindra - RESPETE LAS ALTURAS y DIRECCIÓN. Una vez hecha la alineación, se apagará el indicador luminoso en el receptor

## CARATTERISTICHE TECNICHE - SPECIFICATIONS - TECHNISCHE EINGESHAFFEN - CARACTERISTIQUES TECHNIQUES - CARACTERISTICAS TECNICAS

Alimentazione / Power supply / Spannung / Alimentation / Alimentación	12/24 Vdc-Vac
Portata* / Range* / Senoleberelch* / Portée* / Alcance*	20 mt
Consumo trasmettitore / Power consumption transmitter / Verbrauch Sender / Consommation émetteur / Consumo transmisor	40 (12 Vdc) mA - 60 (24 Vdc) mA 11 (12 Vac) mA - 10 (24 Vac) mA
Consumo ricevitore / Power consumption receptor / Verbrauch Empfänger / Consommation récepteur / Consumo receptor	10 (12 Vdc) mA - 11 (24 Vdc) mA 7 (12 Vac) mA - 6 (24 Vac) mA
Contatto relay in uscita / Output relay contact / Relais-Kontakt am Ausgang / Contact relais à la sortie / Contacto relé en salida	N.C. 500 mA / 24 V
Grado di protezione / Protection level / Schutzart / Degré de protection / Grado de protección	IP 54

\* In caso di particolari condizioni atmosferiche (nebbia, pioggia, neve, etc.) la portata si può ridurre del 60%. \* In case of particular atmospheric conditions (fog, rain, snow, etc.) the range can be reduced of 60%. \* Bei besonderen Wetterverhältnissen (Nebel, Regen, Schnee, etc.) kann die Reichweite bis 60% reduzieren. \* En cas de conditions atmosphériques particulières (brouillard, pluie, neige, etc.) la portée peut se réduire du 60%. \* En caso de condiciones atmosféricas particulares (niebla, lluvia, nieve, etc.) l'alcance se puede reducir del 60%.

## MONTAGGIO - FITTING - MONTAGE - MONTAGE - MONTAJE

- |  |  |  |   |   |
|--|--|--|---|---|
| <p><b>IT</b></p> <p>1 Fissare la base della fotocellule alla colonna o muro usando i fori presenti (A fig. 1). Far passare i cavi tramite i fori (B e C fig. 1) con passacavo PG9 e collegare i cavi alla morsetteria.</p> <p>2 Posizionare la guarnizione in dotazione come indicato in figura 2.</p> <p>3 Prefissare all'interno della base il gruppo lente (D fig.3) con le apposite viti (E fig.3). Regolare l'orientamento, ad allineamento avvenuto il Led sul ricevitore si spegnerà. Fissare definitivamente la lente alla base della fotocellula (E fig.3).</p> <p>4 Chiudere con il coperchio della fotocellula e fissare le viti (fig. 4).</p> <p>4 Chiudere il coperchio inferiore come in figura (fig. 5) e avvertire il "click" di chiusura.</p> | <p><b>EN</b></p> <p>1 Fix the base of the photocells to the column or wall using the drilled holes (A fig. 1). Pass the cables through the holes (B and C fig. 1) with fairlead PG9 and connect the cables to the terminal board.</p> <p>2 Position the supplied gasket as shown in picture 2.</p> <p>3 Pre-fix the lens group on the inside of the base using the screws supplied (E fig.3). Adjust the orientation, when alignment is reached the LED on the receiver will go off. Fix the lens onto the base of the photocell definitely (E fig.3).</p> <p>4 Close with the photocell cover and fix the screws (fig.4).</p> <p>5 Close the lower cover as shown in the figure (fig.5) and listen for the closing "click".</p> | <p><b>DE</b></p> <p>1 Die Basis der Lichtschranken an die Säule oder an die Wand mithilfe der vorliegenden Bohrungen befestigen (A Abb. 1). Die Kabel über die Bohrungen (B und C Abb. 1) mit einem Kabelniederhalter PG9 verlegen und die Kabel an das Klemmbrett anschließen.</p> <p>2 Positionieren Sie die mitgelieferte Dichtung wie in Abbildung 2 gezeigt.</p> <p>3 Die Linsengruppe (D Abb. 3) mit den vorgesehenen Schrauben (E Abb. 3) in die Basis im ersten Schritt befestigen. Die Ausrichtung regulieren – nach erfolgter Anpassung schaltet sich die Led am Empfänger aus. Die Linse definitiv an der Basis der Lichtschranke (E Abb. 3) befestigen.</p> <p>4 Mit dem Deckel der Lichtschranke schließen und die Schrauben befestigen (Abb. 4).</p> <p>5 Den unteren Deckel wie in der Abbildung (Abb. 5) gezeigt schließen und das abschließende "Klick" abwarten.</p> | <p><b>FR</b></p> <p>1 Fixer la base de la cellule photoélectrique à la colonne ou au mur en utilisant les trous présents (A fig.1). Faire passer les câbles au travers des trous (B et C fig. 1) avec le serre-câble PG9 et connecter les câbles au bornier.</p> <p>2 Placer la garniture fournie comme indiqué à la figure 2.</p> <p>3 Préfixer à l'intérieur de la base le groupe verre (D fig.3) avec les vis spéciales (E fig.3). Régler l'orientation, et lorsque l'alignement est terminé le Led sur le récepteur s'éteindra. Fixer définitivement le verre à la base de la cellule photoélectrique (E fig.3).</p> <p>4 Fermer le couvercle de la cellule photoélectrique et fixer les vis (fig. 4).</p> <p>5 Fermer le couvercle inférieur comme sur la figure (fig. 5) jusqu'à entendre le 'clac' de fermeture.</p> | <p><b>ES</b></p> <p>1 Fijar la base de la fotocélula en la columna o en la pared usando los agujeros presentes (A Fig. 1). Hacer pasar los cables por los agujeros (B y C Fig. 1) con sujetacable PG9) y conectar los cables a la regleta.</p> <p>2 Coloque la guarnición en dotación como indicado en la figura 2</p> <p>3 Prefijar en el interior de la base el grupo de lente (D Fig. 3) con los relativos tornillos (E Fig. 3). Regular la orientación, una vez realizada la alineación se apagará el indicador luminoso en el receptor. Fijar definitivamente la lente a la base de la fotocélula (E Fig. 3).</p> <p>4 Cerrar con la tapa de la fotocélula y fijar los tornillos (Fig. 4).</p> <p>5 Cerrar la tapa inferior como muestra la figura (Fig. 5) y oír el «clac» de cierre.</p> |
|--|--|--|---|---|

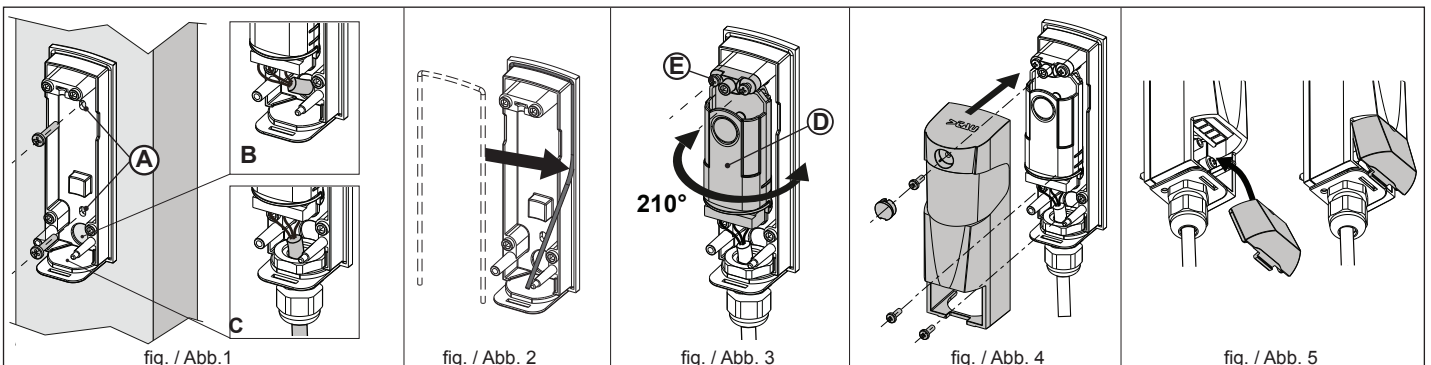

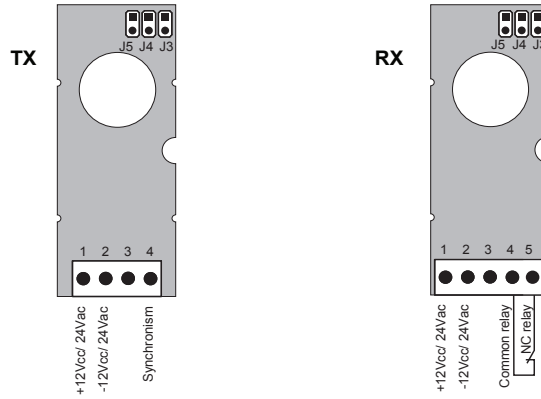

SISTEMA DI SINCRONISMO - SYNCHRONISM SYSTEM - GLEICHLAUFSYSTEM - SYSTÈME DE SYNCHRONISME - SISTEMA DE SINCRONÍA

**IT**  
Se avete la necessità di installare più di una fotocellula molto vicine tra loro è necessario collegarle tutte insieme come indicato nello schema a fianco e codificare i ponticelli (J3, J4, J5) dei dispositivi come in tabella.

0 → ; 1 → ; es. 0 0 1 →

**EN**  
If you need to install more than a photocell near to each other, they need to be connected all together as shown in the diagram on the side and the jumpers (J3, J4, J5) of the devices must be codified as in the table.

0 → ; 1 → ; es. 0 0 1 →

**DE**  
Wenn Sie mehrere Lichtschranken eng nacheinander installieren wollen, müssen sie alle wie im nebenstehenden Schema aufgeführt - angeschlossen und die Brücken (J3, J4, J5) der Vorrichtungen laut Tabelle codiert werden.

0 → ; 1 → ; es. 0 0 1 →

**FR**  
Si vous devez installer plusieurs cellules photoélectriques très proches les unes des autres, il est nécessaire de les connecter ensemble comme indiqué sur le schéma ci-contre et de coder les cavaliers (J3, J4, J5) des dispositifs comme indiqué dans le tableau.

0 → ; 1 → ; es. 0 0 1 →

**ES**  
Si necesitan instalar varias fotocélulas muy cercanas entre ellas es necesario conectarlas todas juntas como se indica en el esquema de al lado y codificar los puentes (J3, J4, J5) de los dispositivos como se muestra en la tabla.

0 → ; 1 → ; es. 0 0 1 →

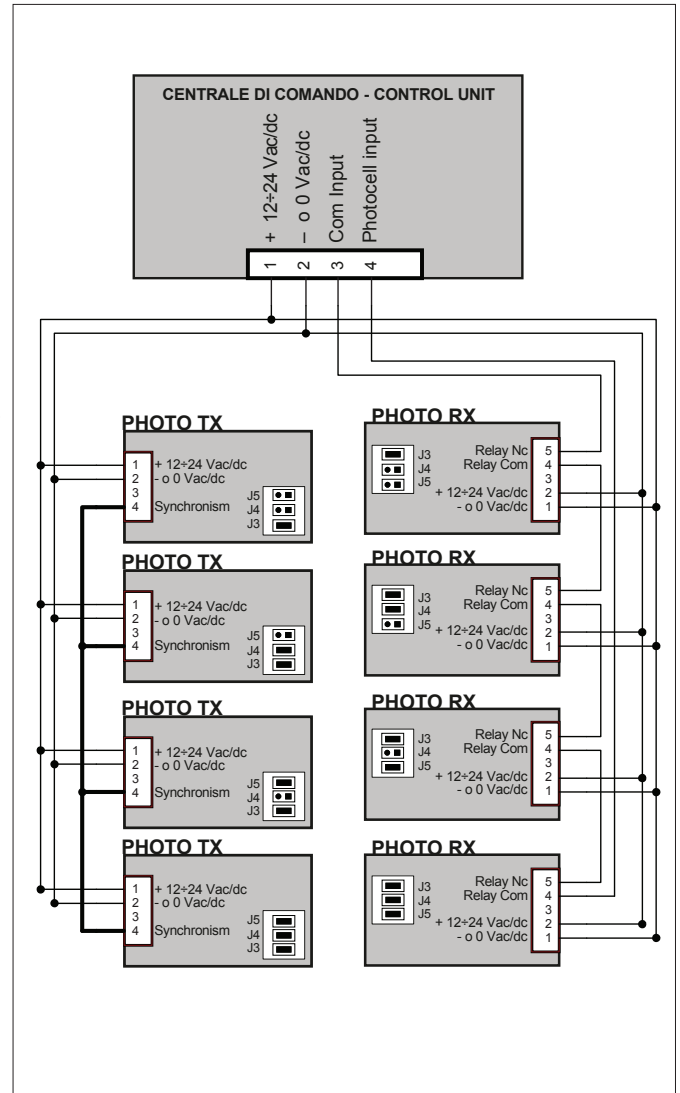

J5	J4	J3	Descrizione - Description - Beschreibung - Description - Descripción
0	0	0	Funzionamento singolo (una sola coppia) - Single operation (one pair only) - Einzelne Funktion (nur ein Paar) - Fonctionnement unique (un seul couple) - Funcionamiento individual (un solo par)
0	0	1	Master abilitato, canale 1 - Enabled master, channel 1 - Befähigtes Master, Kanal 1 - Master autorisé, canal 1 - Master habilitado, canal 1
0	1	1	Slave abilitato, canale 2 - Enabled slave, channel 2 - Befähigtes Slave, Kanal 2 - Slave autorisé, canal 2 - Slave habilitado, canal 2
1	0	1	Slave abilitato, canale 3 - Enabled slave, channel 3 - Befähigtes Slave, Kanal 3 - Slave autorisé, canal 3 - Slave habilitado, canal 3
1	1	1	Slave abilitato, canale 4 - Enabled slave, channel 4 - Befähigtes Slave, Kanal 4 - Slave autorisé, canal 4 - Slave habilitado, canal 4

DICHIARAZIONE CE DI CONFORMITÀ / EC DECLARATION OF CONFIRMITY / EG-KONFORMITÄTserklärung  
DECLARATION CE DE CONFORMITÉ / DECLARACION CE DE CONFORMIDAD

Con la presente dichiariamo che il nostro prodotto / We hereby declare that our product / Hiermit erklaren wir, dass unser Produkt  
Nous déclarons par la présente que notre produit / Por la presente declaramos que nuestro producto: **900PIVOT**

è conforme alle seguenti disposizioni pertinenti: / complies with the following relevant provisions: / folgenden einschlagigen Bestimmungen entspricht:  
correspond aux dispositions pertinentes suivantes: / satisface las disposiciones pertinentes siguientes:

**2006/42/CE, 2014/35/EU, 2014/30/EU** (EN 61000-6-2; EN 61000-6-3)

Il Rappresentante Legale / The legal Representative / Der gesetzliche  
Vertreter / Le Représentant Légal / El Representante Legal

Loris Virgilio Danieli

Sandrigo, 16/04/2018